



CP

Reactive Power Compensation Components

- Three-phase capacitors **402**
- Capacitor duty contactors CEM_CN **412**
- Digital power factor controllers **415**
- Three-phase harmonic filters **419**

CP

Three phase low voltage power capacitors LPC

Equipped with discharge resistors (Discharge time ≤ 3 minutes to 75 V)

Capacitors 1 ... 5 kVar connected with a double FASTON connector
Included protection cover for electrical parts)

LPC 1..5 kVAR

LPC 10..50 kVAR



10 ... 50 kVar capacitor terminals with universal screws (for slot "flat" screwdriver + Allen key "Imbus")

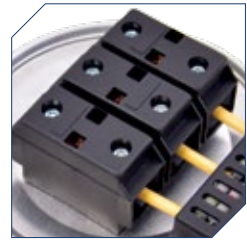

rated power range: 1kVar to 50kVAR

Ground fixation with thread, for vertical use only.

Overpressure disconnection system

Rated voltage range: 400, 440 460, 480, 525 V

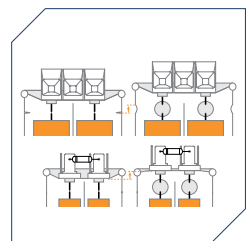

Rated voltage: 400-525V, 50Hz (60Hz upon request)

Rated power: 1-50kVAR

APPLICATION

The LPC capacitors are used for reactive power factor correction of inductive consumers (transformers, electric motors, rectifiers, fluorescent lamps and many others in industrial networks) individually or assembled into automatic capacitor banks.

DESCRIPTION

LPC capacitors are manufactured with low loss metallized self-healing polypropylene film. Dry type capacitors are filled with a non-toxic and ecological polyurethane resin, this resin provides an excellent heat dissipation properties. This capacitors are mounted in aluminium housing with overpressure disconnection system. Two types of connectors, faston connector for capacitors with rated power up to 5kVAR, for higher values above 5kVAR screw terminal type.

FEATURES:

Depending on the values of the constants of every dielectric, there is a limit potential difference, which all materials can manage throughout the thickness. This limit is defined as dielectric strength. Because of determined electric-power system conditions or extreme temperatures, inadmissible for the correct working of the capacitor, this voltage limit can be exceeded. Thus, the dielectric can break down and an electric arc will be formed between the plates.

The propylene film self-healing means that the electric arc will not generate a short circuit, but will evaporate the metal which surrounds the breakthrough point. This way, the isolation between plates is repaired in the latter breakthrough point. After this self-healing, the capacitor can work in normal conditions, with a capacitance leak inferior to 100 pF.

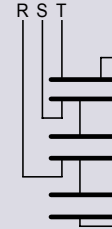

DELTA CONNECTION

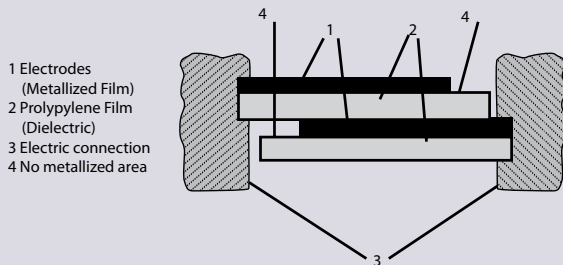
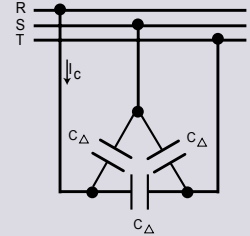

Overpressure disconnection system

In order to avoid problems caused by overvoltage, harmonics, high temperatures, etc. capacitors have been designed with an overpressure disconnection system. When the terminal cover expands, the internal connections are interrupted and disconnecting the capacitor.



Discharge resistor

When handling a capacitor, there is a need of taking into account a series of security precautions. When a capacitor is disconnected off the voltage, it remains charged with the supply voltage. If the plates are shorten and touched, they can cause a dangerous accident due to the violent discharge of the capacitor. Three-phase capacitors must also be equipped with a discharge resistor, which can discharge voltage until its maximum value is 75V in an interval of 3 minutes as demanded by standard EN-60831-1/2. ETI's LPC capacitors already have discharge resistors, which ensure that this time is less than 2 minutes. It is therefore recommended that the reconnection time on the PFC controller should not be less than 120s. Except in case of using extra discharge resistors (page 409).



$$U_{(t)} = U_o e^{-\frac{t}{RC}}$$

Three phase low voltage power capacitors LPC

Rated voltage at 50Hz	Code No.	Type	Rated Power		Rated capacitance		Rated current [A]	D (diameter) x H (Height) [mm]	Terminal type	Weight [kg]	Packaging [pcs]
			[kVAr]		[uF]						
400	004656700	LPC 1 kVAr, 400V, 50Hz	1	3x	6,6		1,4	60x240	Faston	0,75	1
400	004656701	LPC 1.5 kVAr, 400V, 50Hz	1,5	3x	9,9		2,2		Faston	0,75	1
400	004656702	LPC 2.5 kVAr, 400V, 50Hz	2,5	3x	16,6		3,6		Faston	0,75	1
400	004656703	LPC 3 kVAr, 400V, 50Hz	3	3x	19,9		4,3		Faston	0,75	1
400	004656704	LPC 4 kVAr, 400V, 50Hz	4	3x	26,5		5,8		Faston	0,75	1
400	004656705	LPC 5 kVAr, 400V, 50Hz	5	3x	33,2		7,2		Faston	0,75	1
440	004656710	LPC 2.5 kVAr, 440V, 50Hz	2,5	3x	13,7		3,3		Faston	0,75	1
440	004656711	LPC 3 kVAr, 440V, 50Hz	3	3x	16,4		3,9		Faston	0,75	1
440	004656712	LPC 4 kVAr, 440V, 50Hz	4	3x	21,9		5,2		Faston	0,75	1
440	004656713	LPC 5 kVAr, 440V, 50Hz	5	3x	27,4		6,6		Faston	0,75	1
460	004656720	LPC 2.5 kVAr, 460V, 50Hz	2,5	3x	12,5		3,1		Faston	0,75	1
460	004656721	LPC 3 kVAr, 460V, 50Hz	3	3x	15,0		3,8		Faston	0,75	1
460	004656722	LPC 4 kVAr, 460V, 50Hz	4	3x	20,1		5,0		Faston	0,75	1
460	004656723	LPC 5 kVAr, 460V, 50Hz	5	3x	25,1		6,3		Faston	0,75	1
480	004656730	LPC 2.5 kVAr, 480V, 50Hz	2,5	3x	11,5		3,0		Faston	0,75	1
480	004656731	LPC 3 kVAr, 480V, 50Hz	3	3x	13,8		3,6		Faston	0,75	1
480	004656732	LPC 4 kVAr, 480V, 50Hz	4	3x	18,4		4,8	Faston	0,75	1	
480	004656733	LPC 5 kVAr, 480V, 50Hz	5	3x	23,0		6,0	Faston	0,75	1	
525	004656740	LPC 2.5 kVAr, 525V, 50Hz	2,5	3x	9,6		2,7	Faston	0,75	1	
525	004656741	LPC 3 kVAr, 525V, 50Hz	3	3x	11,5		3,3	Faston	0,75	1	
525	004656742	LPC 4 kVAr, 525V, 50Hz	4	3x	15,4		4,4	Faston	0,75	1	
525	004656743	LPC 5 kVAr, 525V, 50Hz	5	3x	19,2		5,5	Faston	0,75	1	

LPC 1 kVAr - LPC 5 kVAr

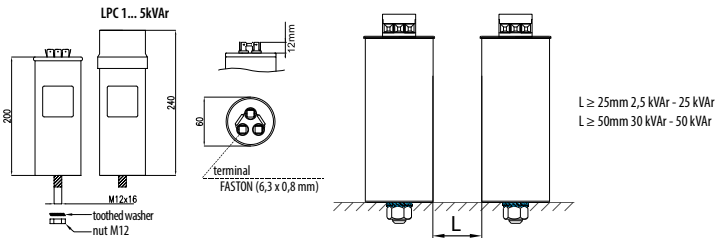

LPC 10 kVAr - LPC 50 kVAr

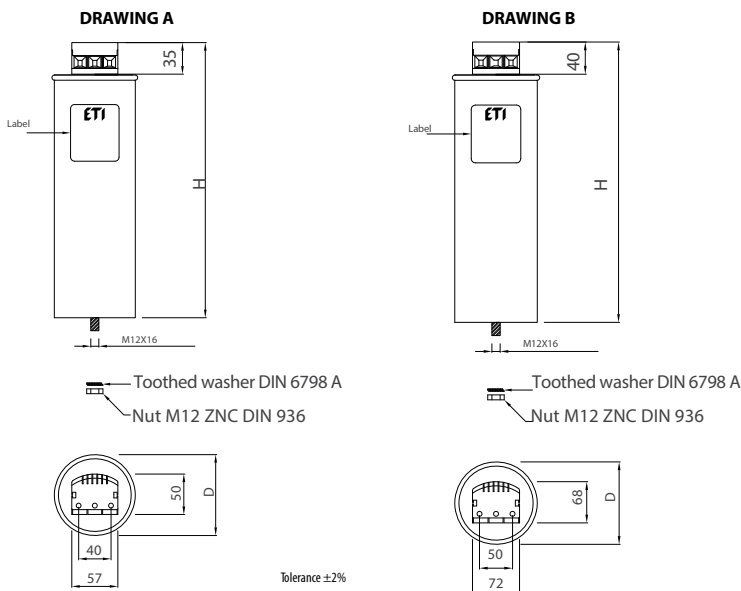

Three phase low voltage power capacitors LPC

Rated voltage at 50Hz	Code No.	Type	Rated Power		Rated capacitance		Rated current [A]	D (diameter) x H (Height) [mm]	Terminal type	Weight [kg]	Packaging [pcs]
			[kVA]	[kVA]	[uF]	[uF]					
400	004656750	LPC 10 kVA, 400V, 50Hz	10	3x	66,3	14,4	85x260	Screw terminal	1,6	1	
400	004656751	LPC 12.5 kVA, 400V, 50Hz	12,5	3x	82,9	18,0	100x260	Screw terminal	2,2	1	
400	004656752	LPC 15 kVA, 400V, 50Hz	15	3x	99,5	21,7	100x260	Screw terminal	2,2	1	
400	004656753	LPC 20 kVA, 400V, 50Hz	20	3x	132,6	28,9	100x260	Screw terminal	2,2	1	
400	004656754	LPC 25 kVA, 400V, 50Hz	25	3x	165,8	36,1	120x350	Screw terminal	2,9	1	
400	004656755	LPC 30 kVA, 400V, 50Hz	30	3x	198,9	43,3	120x350	Screw terminal	3,9	1	
400	004656756	LPC 40 kVA, 400V, 50Hz	40	3x	265,3	57,7	120x350	Screw terminal	5,1	1	
400	004656757	LPC 50 kVA, 400V, 50Hz	50	3x	331,6	72,2	120x350	Screw terminal	5,1	1	
440	004656760	LPC 10 kVA, 440V, 50Hz	10	3x	54,8	13,1	85x260	Screw terminal	1,6	1	
440	004656761	LPC 12.5 kVA, 440V, 50Hz	12,5	3x	68,5	16,4	100x260	Screw terminal	2,2	1	
440	004656762	LPC 15 kVA, 440V, 50Hz	15	3x	82,2	19,7	100x260	Screw terminal	2,2	1	
440	004656763	LPC 20 kVA, 440V, 50Hz	20	3x	109,6	26,2	100x350	Screw terminal	2,9	1	
440	004656764	LPC 25 kVA, 440V, 50Hz	25	3x	137,0	32,8	100x350	Screw terminal	2,9	1	
440	004656765	LPC 30 kVA, 440V, 50Hz	30	3x	164,4	39,4	120x350	Screw terminal	3,9	1	
440	004656766	LPC 40 kVA, 440V, 50Hz	40	3x	219,2	52,5	136x350	Screw terminal	5,1	1	
440	004656767	LPC 50 kVA, 440V, 50Hz	50	3x	274,0	65,6	136x350	Screw terminal	5,1	1	
460	004656770	LPC 10 kVA, 460V, 50Hz	10	3x	50,1	12,6	85x260	Screw terminal	1,6	1	
460	004656771	LPC 12.5 kVA, 460V, 50Hz	12,5	3x	62,7	15,7	100x260	Screw terminal	2,2	1	
460	004656772	LPC 15 kVA, 460V, 50Hz	15	3x	75,2	18,8	100x260	Screw terminal	2,2	1	
460	004656773	LPC 20 kVA, 460V, 50Hz	20	3x	100,3	25,1	100x350	Screw terminal	2,9	1	
460	004656774	LPC 25 kVA, 460V, 50Hz	25	3x	125,4	31,4	100x350	Screw terminal	2,9	1	
460	004656775	LPC 30 kVA, 460V, 50Hz	30	3x	150,4	37,7	120x350	Screw terminal	3,9	1	
460	004656776	LPC 30.8 kVA, 460V, 50Hz	30,8	3x	154,4	38,7	120x350	Screw terminal	3,9	1	
460	004656777	LPC 40 kVA, 460V, 50Hz	40	3x	200,6	50,2	136x350	Screw terminal	5,1	1	
460	004656778	LPC 50 kVA, 460V, 50Hz	50	3x	250,7	62,8	136x350	Screw terminal	5,1	1	
480	004656780	LPC 10 kVA, 480V, 50Hz	10	3x	46,1	12,0	85x260	Screw terminal	1,6	1	
480	004656781	LPC 12.5kVA, 480V, 50Hz	12,5	3x	57,6	15,0	100x260	Screw terminal	2,2	1	
480	004656782	LPC 15 kVA, 480V, 50Hz	15	3x	69,1	18,0	100x260	Screw terminal	2,2	1	
480	004656783	LPC 20 kVA, 480V, 50Hz	20	3x	92,1	24,1	100x350	Screw terminal	2,9	1	
480	004656784	LPC 25 kVA, 480V, 50Hz	25	3x	115,1	30,1	100x350	Screw terminal	3,9	1	
480	004656785	LPC 30 kVA, 480V, 50Hz	30	3x	138,2	36,1	120x350	Screw terminal	3,9	1	
480	004656786	LPC 40 kVA, 480V, 50Hz	40	3x	184,2	48,1	136x350	Screw terminal	5,1	1	
480	004656787	LPC 50 kVA, 480V, 50Hz	50	3x	230,3	60,1	136x350	Screw terminal	5,1	1	
525	004656790	LPC 10 kVA, 525V, 50Hz	10	3x	38,5	11,0	85x260	Screw terminal	1,6	1	
525	004656791	LPC 12.5kVA, 525V, 50Hz	12,5	3x	48,1	13,7	100x260	Screw terminal	2,2	1	
525	004656792	LPC 15 kVA, 525V, 50Hz	15	3x	57,7	16,5	100x260	Screw terminal	2,2	1	
525	004656793	LPC 20 kVA, 525V, 50Hz	20	3x	77,0	22,0	100x350	Screw terminal	2,9	1	
525	004656794	LPC 25 kVA, 525V, 50Hz	25	3x	96,2	27,5	100x350	Screw terminal	2,9	1	
525	004656795	LPC 30 kVA, 525V, 50Hz	30	3x	115,5	33,0	120x350	Screw terminal	3,9	1	
525	004656796	LPC 40 kVA, 525V, 50Hz	40	3x	154,0	44,0	136x350	Screw terminal	5,1	1	
525	004656797	LPC 50 kVA, 525V, 50Hz	50	3x	192,5	55,0	136x350	Screw terminal	5,1	1	

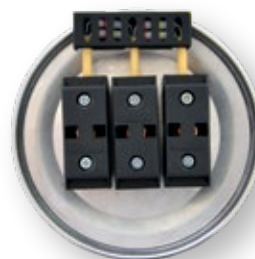

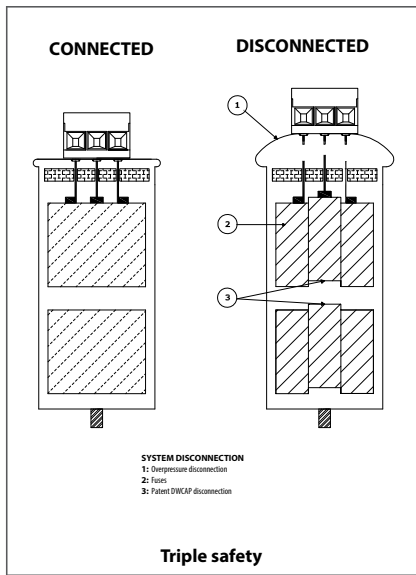

Temperature (IEC 60831-1/2)

Symbol	Ambient temperature °C		
	Maximum	Highest mean over any period of	
		24h	1 year
A	40	30	20
B	45	35	25
C	50	40	30
D	55	45	35

Dimensions

Dimensions	Connection terminal		DRAWING
	Max. cable section 1 kV-RV (mm ²)		
DxH (mm)			DRAWING A
70x260	10		
85x260	10		
100x260	10		DRAWING B
120x265	35		
136x265	35		

Technical data

Standards	IEC 60831-1/2 EN 60831-1/2		
Capacitance tolerance	-5% +10%		
Frequency	50Hz (60Hz upon request)		
Temperature range	-25°C ... +55°C*		
Dielectric losses	≤0.2 W/kVAr		
Total losses	≤0.45 W/kVAr		
Maximum over voltage	1,1 x Un		
Maximum over current	1,5 x In		
Max. THD in voltage	2%		
Max. THD in current	25%		
Discharge resistance	Incorporated; ≤ 2 min to 75V		
Connection	Delta		
Casing	Aluminium case		
Disconnection system	Overpressure		
Dielectric	Metalized polypropylene film, self-healing		
Voltage test between terminals	2,15 x Un 2 sec.		
Voltage test terminals to case	3kV for 10 second. AC		
Terminal type	Connector		
Inrush current	200 x In		
Protection	IP 20, indoor mounting		
Humidity	max 95%		
Expected	120.000 Hrs. (Temp. level C)		
Altitude	Max. 2000 above sea level		
Screw terminal Tightening torque	≤ 20 kVAr 100Ncm ≥ 25kVAr 250Ncm		
Ambient temperature °C	Max	Highest mean over any period of	
		24h	1 year
		55	45

*Special declaration for lower temperature (-40°C) available on request

Cable cross section

Q _n (kVAR)	Un		Terminal	Connection
	400V, 50Hz			
	I _n (A)	(mm ² , Cu)		
2,5	3,6	2,5		
5	7,4	2,5		
7,5	10,8	2,5		
10	14,4	4,0		
12,5	18,1	6,0		
15	21,6	6,0		
20	29,0	10,0		
25	36,0	10,0		
30	43,0	16,0		
40	58,0	25,0		
50	72,0	35,0		

Cross – section values of the connection wires shown in the table are approximate and they are valid for normal operation conditions due to technical characteristics of the equipment.

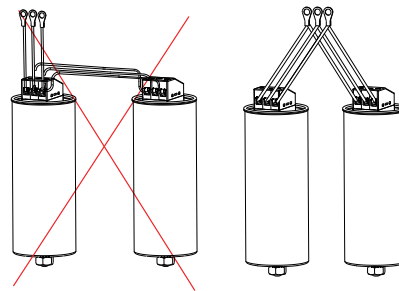
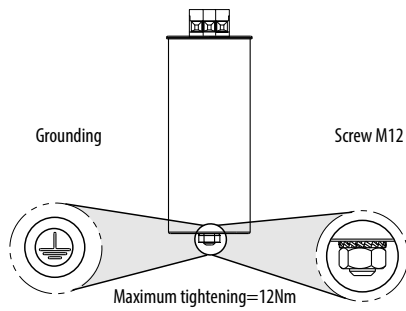

⚠ ATTENTION! Parallel interconnection of two or more capacitors through the same terminals is prohibited.

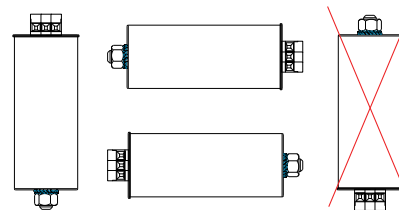
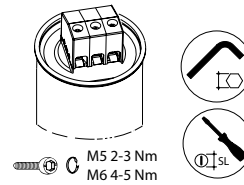

Three phase low voltage power capacitors LPC with double winding

Advantages:

- /// Extra low size capacitors
- /// Triple safety
- /// Patented technology

Characteristics and utility:

- /// Three phase capacitor dual winding internally delta connected
- /// Discharge resistors incorporated
- /// Reactive power factor correction
- /// Dry type
- /// Connector type terminal
- /// Indoor mounting

Triple safety:

- /// Overpressure disconnection system
- /// Protection by internal fuses
- /// DWCAP system (patented) internal windings displacement

Construction and materials:

- /// Low losses metallized self-healing polypropylene film, high density, high temperature and greater dielectric resistance volt/μ
- /// Polyurethane self-extinguishing resin VO, developed under standard UL94
- /// Aluminium case with bottom fixing M12x16

Standards:

- /// IEC 60831-1/2
- /// EN 60831-1/2

Certifications:

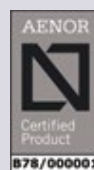

Three phase low voltage power capacitors LPC with double winding

Rated voltage at 50Hz	Code No.	Type	Rated Power		Rated current [A]	D (diameter) x H (Height) [mm]	Terminal type	Weight [kg]	Packaging [pcs]
			[kVAr]	[uF]					
400V	004656850	LPC-DW 7.5 kVAr, 400V, 50Hz	7,5	3x 49,74	10,83	70 x 260	Screw terminal	1,1	1
400V	004656851	LPC-DW 10 kVAr, 400V, 50Hz	10	3x 66,31	14,43	85 x 260		1,62	1
400V	004656852	LPC-DW 12.5 kVAr, 400V, 50Hz	12,5	3x 82,89	18,04	85 x 260		1,62	1
400V	004656853	LPC-DW 15 kVAr, 400V, 50Hz	15	3x 99,47	21,65	100 x 260		2,11	1
400V	004656854	LPC-DW 20 kVAr, 400V, 50Hz	20	3x 132,63	28,87	120 x 265		3,23	1
400V	004656855	LPC-DW 25 kVAr, 400V, 50Hz	25	3x 165,79	36,08	120 x 265		3,13	1
400V	004656856	LPC-DW 30 kVAr, 400V, 50Hz	30	3x 198,94	43,3	136 x 265		4,01	1
400V	004656857	LPC-DW 35 kVAr, 400V, 50Hz	35	3x 232	50,5	136 x 265		4,2	1
400V	004656867	LPC-DW 40 kVAr, 400V, 50Hz	40	3x 265	57,7	136 x 265		4,2	1
440V	004656858	LPC-DW 7.5 kVAr, 440V, 50Hz	7,5	3x 41,1	9,84	70x260		1,2	1
440V	004656859	LPC-DW 10 kVAr, 440V, 50Hz	10	3x 54,81	13,12	70x260		1,1	1
440V	004656860	LPC-DW 12.5 kVAr, 440V, 50Hz	12,5	3x 68,51	16,4	85x260		1,6	1
440V	004656861	LPC-DW 15 kVAr, 440V, 50Hz	15	3x 82,21	19,68	85x260		1,6	1
440V	004656862	LPC-DW 20 kVAr, 440V, 50Hz	20	3x 109,61	26,24	100x260		2,08	1
440V	004656863	LPC-DW 25 kVAr, 440V, 50Hz	25	3x 137,01	32,8	120x265		3,21	1
440V	004656864	LPC-DW 30 kVAr, 440V, 50Hz	30	3x 164,42	39,36	120x265		4,07	1
440V	004656865	LPC-DW 35 kVAr, 440V, 50Hz	35	3x 191,82	45,93	136x265		4,11	1
440V	004656866	LPC-DW 40 kVAr, 440V, 50Hz	40	3x 219,22	52,49	136x265		4	1

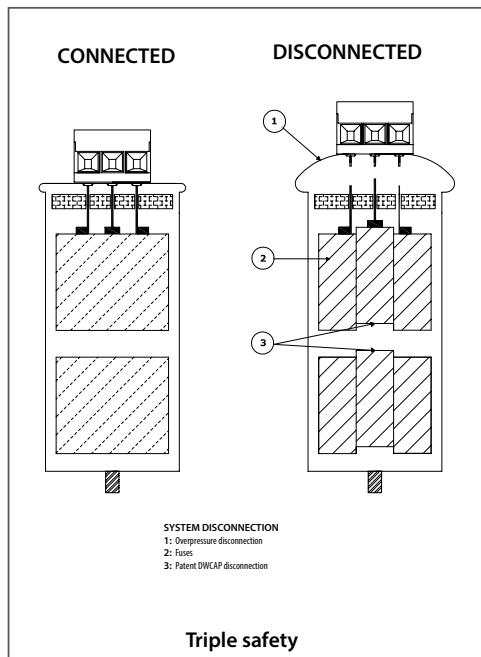

Temperature (IEC 60831-1/2)

Symbol	Ambient temperature °C		
	Maximum	Highest mean over any period of	
		24h	1 year
A	40	30	20
B	45	35	25
C	50	40	30
D	55	45	35

Dimensions

Dimensions	Connection terminal		DRAWING
	Max. cable section 1 kV-RV (mm²)		
70x230	10		DRAWING A
85x230	10		
100x230	10		
120x230	35		DRAWING B
136x230	35		

Technical data

Standards	IEC 60831-1/2 EN 60831-1/2		
Capacitance tolerance	-5% +10%		
Frequency	50Hz (60Hz upon request)		
Temperature range	-25°C ... +55°C*		
Dielectric losses	≤0.2 W/kVAr		
Total losses	≤0.45 W/kVAr		
Maximum over voltage	8 h/day: 30 min/day: 5 min/day: 1 min/day:		
Maximum over current	1,5 x I _n		
Max. THD in voltage	2%		
Max. THD in current	25%		
Discharge resistance	Incorporated		
Connection	Delta		
Voltage test between terminals	2,15 x U _n 2 sec.		
Voltage test terminals to case	3kV for 10 second. AC		
Inrush current	≤ 200 x I _n		
Protection	IP 20		
Humidity	max. 95%		
Expected	100.000 Hrs. (Temp. level D) 120.000 Hrs. (Temp. level C)		
Altitude	Max. 2000 above sea level		
Mounting position	Universal		
Ambient temperature °C	max.	Highest mean over any period of	
		24h	1 year
		55	45 35

*without resistors

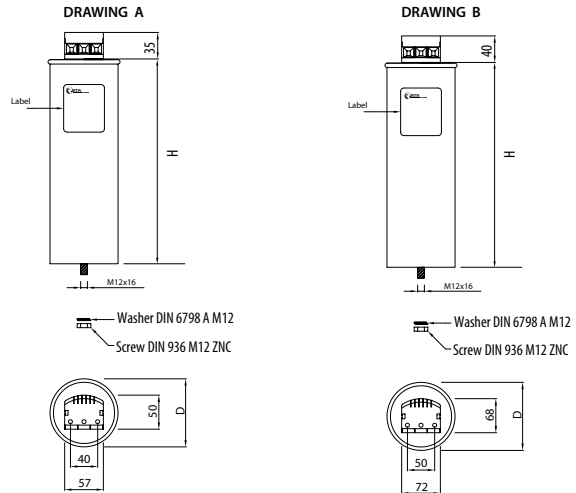

Extra discharge resistors for fast and secure discharge of capacitors

Set of 2 extra discharge resistors for fast and secure discharge of capacitors

Type	Code No.	Resistance [ohm]	Power [W]	Weight [g]	Packaging [pcs]
LPC EDR 1K8, 10W	004656798	1K8	10	30	200

To connect extra discharge resistors, 2 auxiliary contacts NC on capacitor duty contactor must be used

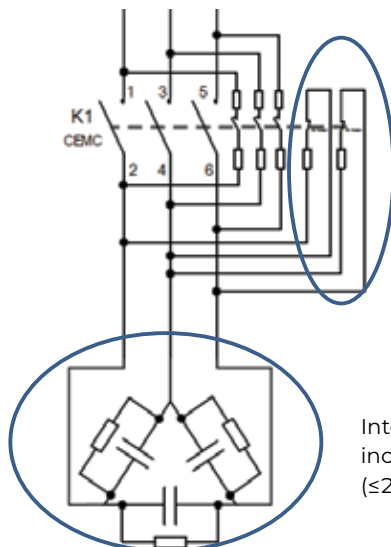

Extra discharge resistors 1K8 10W with auxiliary NC contacts (capacitor empty in less then 5s)

Integrated discharge resistors already included with capacitor for slow discharge (≤2min to 75V demand by IEC 60831 - 1/2)



Individual Power Factor Correction for Low Voltage Motors

Rated motor power [kW]	Power rating of capacitor in (kvar) with respect to motor power, speed of rotation and load									
	3000 r/min		1500 r/min		1000 r/min		750 r/min		500 r/min	
	No load(kVAr)	Full load (kVAr)	No load(kVAr)	Full load (kVAr)	No load(kVAr)	Full load (kVAr)	No load(kVAr)	Full load (kVAr)	No load(kVAr)	Full load (kVAr)
5,5	2,2	2,9	2,4	3,3	2,7	3,6	3,2	4,3	4	5,2
7,5	3,4	4,4	3,6	4,8	4,1	5,4	4,6	6,1	5,5	7,2
11	5	6,5	5,5	7,2	6	8	7	9	7,5	10
15	6,5	8,5	7	9,5	8	10	9	12	10	13
18,5	8	11	9	12	10	13	11	15	12	16
22	10	12,5	11	13,5	12	15	13	16	15	19
30	14	18	15	20	17	22	22	25	22	28
37	18	24	20	27	22	30	26	34	29	39
45	19	28	21	31	24	34	28	38	31	43
55	22	34	25	37	28	41	32	46	36	52
75	28	45	32	49	37	54	41	60	45	68
90	34	54	39	59	44	65	49	72	54	83
110	40	64	46	70	52	76	58	85	63	98
132	45	72	53	80	60	87	67	97	75	110
160	54	86	64	96	72	103	81	116	91	132
200	66	103	77	115	87	125	97	140	110	160
250	75	115	85	125	95	137	105	150	120	175

It is useful to compensate rarely switched low voltage motors with a fixed connected capacitor due to technical and cost reasons.

Description - The required capacitor power is calculated with the following formula:

$$Q_n = 0,9 \cdot U_n \cdot I_{mag} \cdot \sqrt{3}$$

where:

Q_n - capacitor power (VAr)

U_n - rated voltage (V)

I_{mag} - motor magnetising current (A)

Quick discharging with a bigger capacitor can cause self-excitation. If quick discharging of the motor is not possible, the motor can compensate itself according to the actual consumption of reactive power.

Capacitor power versus working voltage

Rated voltage	Rated capacity (µF)	Rated Power (kVAr)	Rated Power (kVAr)	Rated Power (kVAr)	Rated Power (kVAr)
		at $U_e = 380 V$	at $U_e = 400 V$	at $U_e = 420 V$	at $U_e = 440 V$
400 V 50 Hz	3 x 16,6	2,3	2,5	-	-
	3 x 19,9	2,7	3	-	-
	3 x 26,5	3,6	4	-	-
	3 x 33,2	4,5	5	-	-
	3 x 66,3	9,0	10	-	-
	3 x 83,3	11,3	12,5	-	-
	3 x 100	13,6	15	-	-
	3 x 133,0	18,1	20	-	-
	3 x 165,8	22,6	25	-	-
	3 x 198,9	27,1	30	-	-
440 V 50 Hz	3 x 13,7	1,9	2,1	2,3	2,5
	3 x 16,5	2,2	2,5	2,7	3
	3 x 21,9	3,0	3,3	3,6	4
	3 x 27,4	3,7	4,1	4,6	5
	3 x 54,9	7,5	8,3	9,1	10
	3 x 68,6	9,3	10,3	11,4	12,5
	3 x 82,3	11,2	12,4	13,7	15
	3 x 110,0	14,9	16,5	18,2	20
	3 x 137,1	18,6	20,7	22,8	25
	3 x 164,4	22,4	24,8	27,3	30

Capacitor working power depends on working voltage

$$(U_e / U_n)^2 \cdot Q_c = Q_f$$

where:

U_e - mains voltage;

U_n - capacitor rated voltage

Q_c - capacitor power at rated voltage

Q_f - capacitor actual power

Table definition of reactive power capacitor bank (kVAr), necessary to achieve a desired cos

The value of factor K read from table should be multiplied with the value of active power to determine kVAr required for power factor correction.

Capacitive reactive power is calculated by formula:

$$Q_c = P \cdot K$$

P – real power of the load

cos φ₀ – cos φ the system without power factor correction

cos φ₁ – required cos φ achieved with power factor correction

Q_c – reactive power of compensation system

K – factor read from table defined by cos φ₀ and cos φ₁ (see table below)

Existing power factor cos φ ₀	Required power factor cos φ ₁												
	0,7	0,75	0,8	0,82	0,84	0,86	0,88	0,9	0,92	0,94	0,96	0,98	1,00
0,5	0,71	0,85	0,98	1,03	1,09	1,14	1,19	1,25	1,31	1,37	1,44	1,53	1,73
0,52	0,62	0,76	0,89	0,94	1	1,05	1,1	1,16	1,22	1,28	1,35	1,44	1,64
0,54	0,54	0,68	0,81	0,86	0,91	0,97	1,02	1,07	1,13	1,2	1,27	1,36	1,56
0,56	0,46	0,6	0,73	0,78	0,83	0,89	0,94	1	1,05	1,12	1,19	1,28	1,48
0,58	0,38	0,52	0,65	0,71	0,76	0,81	0,86	0,92	0,98	1,04	1,11	1,2	1,4
0,6	0,31	0,45	0,58	0,64	0,69	0,74	0,79	0,85	0,91	0,97	1,04	1,13	1,33
0,62	0,25	0,38	0,52	0,57	0,62	0,67	0,73	0,78	0,84	0,9	0,97	1,06	1,27
0,64	0,18	0,32	0,45	0,5	0,55	0,61	0,66	0,72	0,77	0,84	0,91	1	1,2
0,66	0,12	0,26	0,39	0,44	0,49	0,54	0,6	0,65	0,71	0,78	0,85	0,94	1,14
0,68	0,06	0,2	0,33	0,38	0,43	0,48	0,54	0,59	0,65	0,72	0,79	0,88	1,08
0,7		0,14	0,27	0,32	0,37	0,43	0,48	0,54	0,59	0,66	0,73	0,82	1,02
0,72		0,08	0,21	0,27	0,32	0,37	0,42	0,48	0,54	0,6	0,67	0,76	0,96
0,74		0,03	0,16	0,21	0,26	0,32	0,37	0,42	0,48	0,55	0,62	0,71	0,91
0,76			0,11	0,16	0,21	0,26	0,32	0,37	0,43	0,49	0,56	0,65	0,86
0,78			0,05	0,1	0,16	0,21	0,26	0,32	0,38	0,44	0,51	0,6	0,8
0,8				0,05	0,1	0,16	0,21	0,27	0,32	0,39	0,46	0,55	0,75
0,82					0,05	0,1	0,16	0,21	0,27	0,34	0,41	0,49	0,7
0,84						0,05	0,11	0,16	0,22	0,28	0,35	0,44	0,65
0,86							0,05	0,11	0,17	0,23	0,3	0,39	0,59
0,88								0,06	0,11	0,18	0,25	0,34	0,54
0,9									0,06	0,12	0,19	0,28	0,48
0,92										0,06	0,13	0,22	0,43
0,94											0,07	0,16	0,36

Calculations

Three-phase capacitor power:

$$Q_c = C \cdot 3 \cdot V^2 \cdot 2 \cdot \pi \cdot f_n$$

Example: 3 x 331.5µF at 400V/50Hz
 0.0003315 · 3 · 400² · 314.16 = 50 kVAr

The resonant frequency (fr) and filtering factor (p) in systems with compensation filters:

$$f_r = f_n \cdot \sqrt{\frac{1}{p}} \quad \text{or} \quad p = \left(\frac{f_n}{f_r}\right)^2$$

Example: for p = 0.07 at 50 Hz; fr = 189 Hz
 The calculation of the power factor cos :

$$\cos \varphi = \frac{P}{S} \quad \text{or} \quad \cos \varphi = \frac{1}{\sqrt{1 + \tan^2 \varphi}} \quad \text{or} \quad \cos \varphi = \frac{1}{\sqrt{1 + \left(\frac{Q}{P}\right)^2}}$$

Fuse selection (gG):

In=1,6*I

For Umain=400V, Un=min. 690V

Three-phase capacitor power with detuning reactor in series

$$Q_c = \frac{C \cdot 3 \cdot V^2 \cdot 2 \cdot \pi \cdot f_n}{1 - p}$$

Example: 3 x 331.5µF at 400V/50Hz at p = 7%

0.0003315 · 3 · 400² · 314.16 / 1 - 0.07 = 53.8 kVAr

Phase current of capacitor:

$$I = \frac{Q_c}{V \cdot \sqrt{3}} \quad \text{or} \quad Q_c = I \cdot V \cdot \sqrt{3}$$

Example: 25 kVAr at 400V
 25000 / (400 · 1.73) = 36 A

V = Rated voltage (V)

I = Rated current (A)

fn = Line frequency (Hz)

fr = Resonance frequency (Hz)

p = Filtering factor

Qc= Capacitor power (VAr)

C = Capacitance (F, farad)

P = Active power (W)

S = Apparent power (VA)

Q = Reactive Power (VAr)

In = Rated current of fuse (A)

Un= Rated voltage of fuse (V)

Example: Qc=25kVAr, Umain=400V.

In=1,6*36 = 57,6 => 63A , Un=690V, gG fuse.

CP

Contactors for capacitor banks CEM CN

Application

Contactors for capacitor switching were specially designed for power factor correction capacitor operation (utilization category AC-6b). Capacitors are pre-charged through resistors that reduce the peak current to the contactor when CEM_CN special contactors are switched on. After the pre-charge, the main contactors close allowing passage of rated current.

Advantages

- // Mounting on DIN rails and on mounting plates
- // Technical specification according to IEC 60947-4
- // Built-in pre-charge resistors
- // High reliability
- // Reduced dimensions
- // Standard control voltage 230V AC



CEM 25CN



CEM 32CN



CEM 50CN



CEM 60CN



CEM 80CN

Capacitor duty contactor CEM_CN

Type	Code No.	Rated oper. power 380/415V (kVAr)	Aux. contacts built-in	Weight [g]	Packaging [pcs]
CEM7,5CN.11-230V-50Hz	004643800	7,5	1NC+1NO	345	1
CEM10CN.11-230V-50Hz	004643801	10	1NC+1NO	345	1
CEM18CN.10-230V-50Hz	004644130	15	1NO	619	1
CEM25CN.10-230V-50Hz	004645130	20	1NO	619	1
CEM32CN.10-230V-50Hz	004646130	25	1NO	670	1
CEM50CN.10-230V-50Hz	004648140	40	1NO	1370	1
CEM65CN.10-230V-50Hz	004649140	50	1NO	1389	1
CEM80CN.10-230V-50Hz	004650140	61	1NO	1700	1

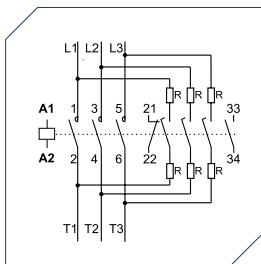

CEM7,5CN...CEM10CN

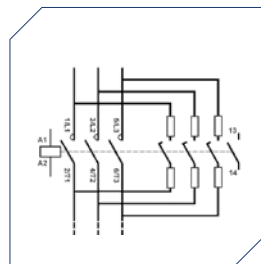

CEM18CN...CEM65CN

Operating principle:

When capacitor bank being switched on, the capacitors are uncharged and the system sees them as a short circuit for a quick period of time. The in-rush current is the result of this little short circuit and usually lasts for some milliseconds. It may reach 100 times the rated current, being one of the main reasons for the short life of a capacitor.

The CEM CN contactor is assembled with damping resistors which limit the high in-rush current when the capacitors are switched on. They are assembled with an early-make contact block, which is switched on before the main contacts, thus, limiting the in-rush current.

However, the damping resistors don't influence the final load, since they are switched off after 5 milliseconds, leaving only the capacitors in parallel with your inductive load, providing the proper power factor correction. This process increases the lifetime of the capacitors and also prevents net distortions.

Capacitor duty contactor CEM CN (230 V 50/60 Hz)

			CEM7,5CN.11- 230V-50Hz	CEM10CN.11- 230V-50Hz	CEM18CN.10- 230V-50Hz	CEM25CN.10- 230V-50Hz	CEM32CN.10- 230V-50Hz	CEM50CN.10- 230V-50Hz	CEM65CN.10- 230V-50Hz	CEM80CN.10- 230V-50Hz
Voltage(V)/ rated power (kVAr)	220-230V	kVAr	4 (230V)	5 (230V)	8	11	15	25	30	35
	380-415V	kVAr	7,5 (400V)	10 (400V)	15	20	25	40	50	61
	440V	kVAr	7,5	10	16	23	30	45	60	71
AC-6b (t° = 55°C)	480V	kVAr	9 (500V)	12,5	17	25	33	50	65	77
	660-690V	kVAr	11	22	25	34	45	65	87	106
AC-6b utilization category(Ie)	(55°C)	A	11	22	21	30	40	60	77	93
AC-6b utilization category(Ie)	(70°C)	A	-	-	15	22	34	50	62	67
Recommended max. fuse (gL/gG)		A	25	35	35	50	63	100	125	160
Cross section		mm ²	1,5...6	1,5...6	6	2 x 10	2 x 16	2 x 35	2 x 35	35
Tightening torque		Nm	1,2	1,2	1 ... 1,7	1,6 ... 3	2,5 ... 4	4 ... 6	4 ... 6	5 ... 6,5
Max electrical operating frequency op/h**				240			120			
Auxiliary contacts built-in			1xNO, 1xNC	1xNO, 1xNC	1xNO	1xNO	1xNO	1xNO	1xNO	1xNO
Electrical lifespan	..x10 ³		250	250			100			
Dimensions (W/H/D)		mm	45/101/108	45/101/108	45/113/129	45/113/129	55/125/140	66/185/158	66/185/158	75/185/167
Code No.			004643800	004643801	004644130	004645130	004646130	004648140	004649140	004650140
Weight		g	345	345	619	619	670	1370	1389	1700

*Accessories (aux. contacts for CEM18CN - CEM80CN and other accessories) can be found in ETICON, page 279

**Recharge time should not be less than 1 minute

Auxiliary contact block - lateral - for CEM7,5 and CEM10CN

Type	Code No.	Description	For use with	Wiring diagram	Weight [g]	Packaging [pcs]
BCMLE11	004643802	1NO + 1NC	CEM7,5CN & CEM10CN		50	2

CP / Capacitor duty contactors

CEM 7,5CN, CEM 10CN

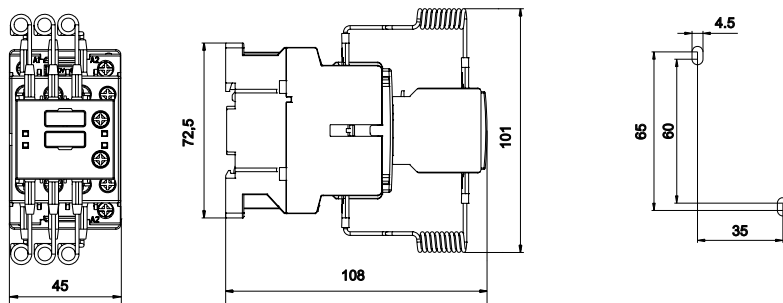

CEM 18CN, CEM 25CN

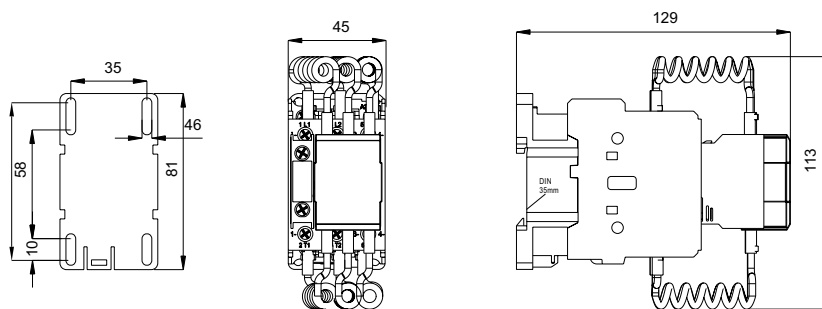

CEM 32CN

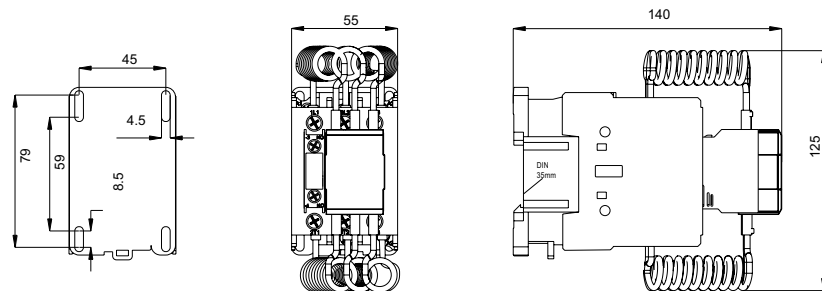

CEM 50CN, CEM 65CN

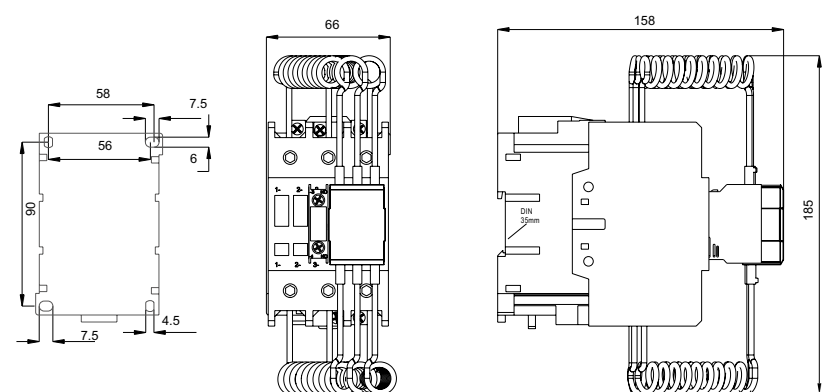

CEM 80CN

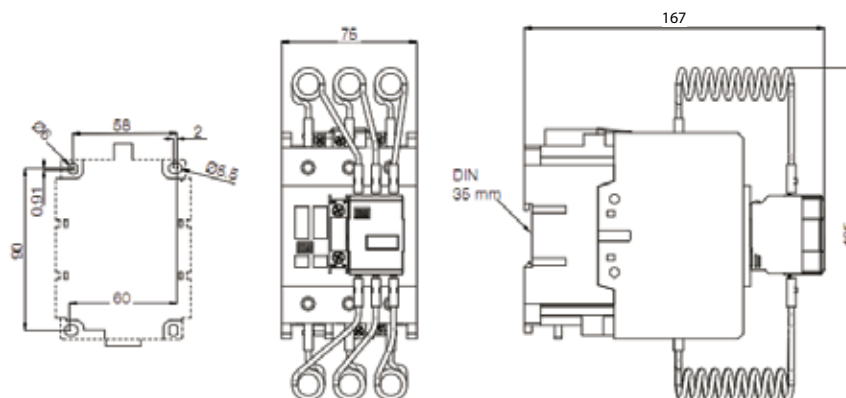

CP

Power factor controllers

Automatic power factor correction controller series PFC 6, 8, 12 RS

Description

An essential way of electrical energy cost reduction is the compensation of the reactive power caused by various type of loads. The main part of central and group power factor correction in systems with a variable load is the power factor controller. A proper power factor controller and the correct design of PFC (Power factor correction) system are the key to the reduction of reactive energy costs. Nowadays, when four-quadrant energy meters are used, the right power factor controller is essential to achieve the highest efficiency of PFC system. Reliable, smart and advanced ETI controllers assure effective reduction of reactive energy and long working life of PFC systems.

MAIN ADVANTAGES

- // Circular usage of steps: The controller switches all steps that have the same power circularly in order to use them equally and prolong their working life time.
- // Fast action: Optimal regulation is achieved in one regulation cycle with a minimum number of switched stages. Since the controller knows the needed compensation power, it can connect or disconnect several steps in one cycle.

REGULATION METHODS:

The power factor controller digitalizes measured phase voltage and phase current in one or three phases. From these values the controller then calculates power factor, effective values of voltage, current and powers. On the basis of allowed reactive power, which is set as a requested power factor value, the controller calculates the requested compensation power. In accordance with its size and direction, the controller connects or disconnects the appropriate capacitor steps.

- // APFR (average power factor regulation): The controller quantifies an average power factor from active and apparent power over a defined period. This method assures that the controller reacts smartly to load changes taking into account the size of load and $\cos \phi$. Thanks to the APFR system, the power factor controller reduces the number of switching operations together with a precisely kept requested power factor result.
- // SHTD: This method uses the deceleration of time to reaction according to the size of the difference between the target power factor and instantaneous value. For every second of difference the time to the reaction is reduced by the square of difference until 0 (the moment of reaction).
- // Instantaneous power factor: This method reacts to every change of the instantaneous power factor by the connection or disconnection of the exact size of reactive power step. This method is mainly used for the dynamic power factor correction system based on thyristor switching modules.

Advantages:

- // monitoring of U, I, P, Q, S, $\cos \phi$, THDU, THDI, odd harmonics up to the 19th order, temperature
- // three regulation methods (APFR default)
- // small design 97 x 97 mm for pannel mounting, PFC 6 RS and PFC 8 RS
- // automatic or manual configuration of measuring circuit connection (load must not vary during the auto-detection process).
- // automatic or manual detection of connected capacitor steps
- // universal current transformer input $\dots/1A$ and $\dots/5A$
- // internal temperature sensor
- // temperature levels for ventilator control and steps disconnection
- // ready for applications with de-compensation reactor steps
- // monitoring of switching operations and operation time
- // setting of discharging and min. operation time for each step
- // memory for min. and max. values
- // discharging time and min. operation time setting for each step
- // last step output programmable for alarm purposes
- // second tariff activation by external input, PFC 12 RS only
- // programmable alarms and independent alarm output at PFC 12 RS only

Controllers for compensation of 3 phase balanced loads (single phase current measurement)

Power factor controllers PFC 6 (6 outputs), PFC 8 (8 outputs) and PFC 12 (12 outputs) are designed for usage in standard LV and MV power factor correction applications operated by mechanical contactors. Despite the small size of power factor controllers, they offer four quadrant measurement and regulation, automatic detection of measuring circuits and capacitor steps, high sensitivity, reliability and design for the hardest conditions.



Technical data

Supply and measuring voltage	400 VAC (+10%, -15%)
System frequency	50 Hz / 60 Hz
Power consumption	<3,2VA
Current range	5mA - 6A
Current input accuracy	± 0,2%
Voltage input accuracy	± 0,5%
THD _v and THD _i accuracy	(U>10%UN) ±5% / (I>10%IN) ±5%
Phase error for I>3%In	± 3° (otherwise ±1°)
Switching power of relay output	250 V AC / 5 A
Range of requested power factor	0.8 inductive ÷ 0.8 capacitive
Step reconnection delay	5 ÷ 900 s
Step disconnection delay	5 ÷ 900 s
Step power setting	999 kVAr inductive ÷ 999 kVAr capacitive
System connection detection	manual / automatic
Communication interface	RS485 (Modbus RTU)
Working temperature	-40°C ÷ +70°C
IP rating	IP20 rear, IP54 front panel
Site depth	55mm
Related norms	EN 61010-1, EN50081-1, EN50082-1

Type	Code No.	Rated voltage Un	Description	Communication module	Weight (kg)	Packaging (pcs)
PFC 6 RS	004656905	400 V AC (+10%, -15%)	Single phase current measurement	RS485	0,65	1
PFC 8 RS	004656906				0,65	1
PFC 12 RS	004656907				1,2	1

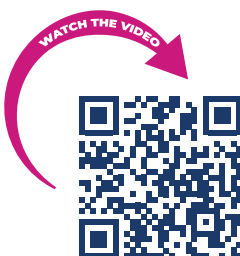

Technical data

Type	Number of steps	Measuring and supply voltage	LED segment display	Tariff input	Alarm output	Last step alarm output	3-ph current measurement	RS 485 communication module	Front panel dimension	Panel cutout
PFC 6 RS	6	400 V AC	✓	—	—	•	—	•	97x97mm	91x91mm
PFC 8 RS	8			—	—	•	•	97x97mm	91x91mm	
PFC 12 RS	12			•	•	•	•	144x144mm	138x138mm	

Over temperature control

The controller offers the possibility of the temperature alarm working in two levels. The first level starts the ventilation of the cabinet. The second level disconnects all steps and gives an alarm notification on the display.

Symbol menu

Every parameter in the monitoring and service menu is represented by a three or four character symbol. Symbols are logical and assure user friendly experience and an easy understanding of all parameters and measured values shown on the segment display.

Dichromatic LED indication

Each step of the controller has an operation status indicated by a dichromatic LED. Different colours and logical signalization identify the operation status and settings of each step.

Last step alarm output PFC 6 RS, PFC 8 RS

The last step normally functions as a standard compensation step. Nevertheless it can be removed from the regulation algorithm and enabled for alarm purposes. The configuration of the last step operated as an alarm output is easily done in the setup menu.

RS485 interface

The power factor controllers are equipped with the RS485 communication interface with communication protocol Modbus RTU.

Harmonics measurement

The controllers offer a wide range of monitoring features which are enlarged by THDU, THDI and also the particular odd harmonics of U and I up to the 19th order.

De-compensation

The controllers have features for smart decompensation with several reactor steps operated in a similar way as capacitor steps or only one reactor that is tuned by capacitor steps.

Tariff input, PFC 12 RS

The power factor controller has an input for the second tariff of cos . The value of the second tariff cos can be defined in the controller's service menu. Applying the signal to input activates the second tariff of cos .

Wiring diagrams of automatic PFC system

PFC 6 electrical scheme

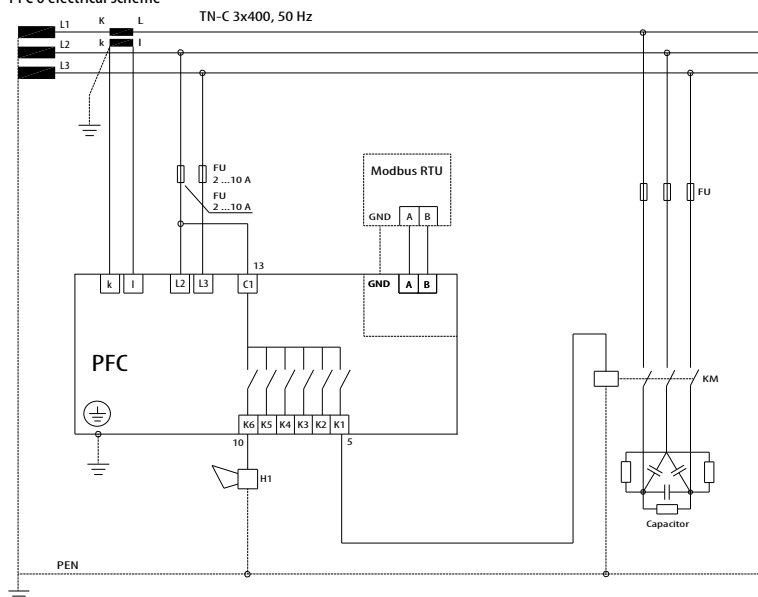

*Capacitor steps with the same power have to be connected next to each other (no different values between).

**Before current circuit disconnection make short-out of CT.

PFC 8 electrical scheme

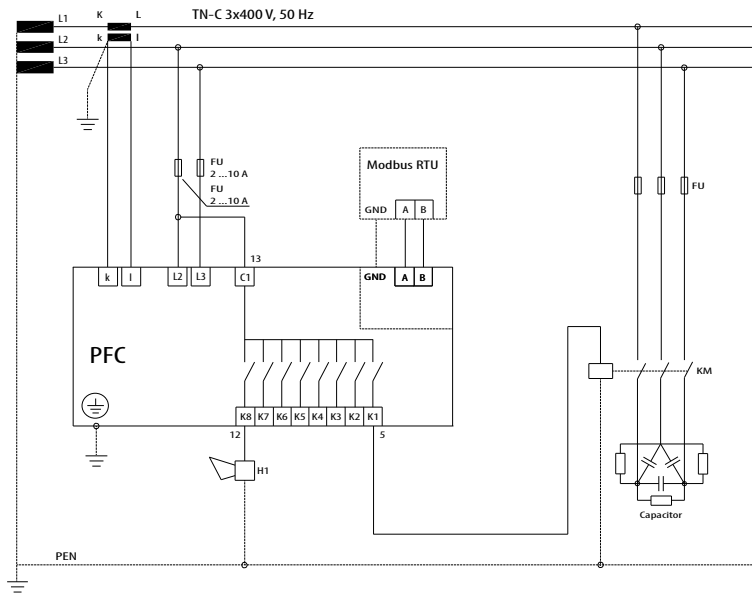

*Capacitor steps with the same power have to be connected next to each other (no different values between).
 **Before current circuit disconnection make short-out of CT.

PFC 12 electrical scheme

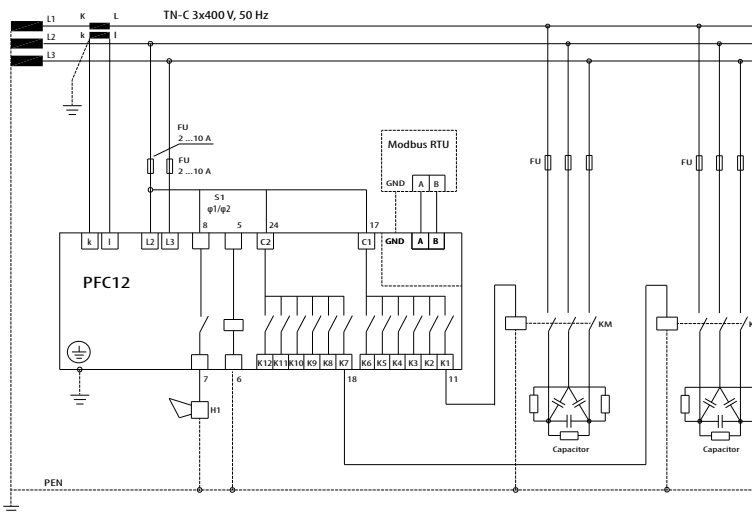

*Capacitor steps with the same power have to be connected next to each other (no different values between).
 **Before current circuit disconnection make short-out of CT.

Position of controller

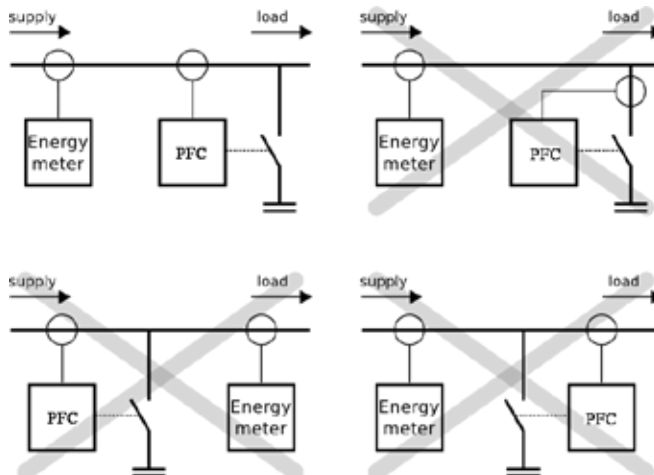



Three-phase harmonic filters

Technical data

Compliance standard	IEC-60289;IEC-076
Tolerance "L"	3%
Permissible overload	1,07 x In
Linearity Inductance	1,60 x In
Heat insulation	F (155°C)
Thermal protection	90°C
Room temperature	45°C
Proof stress	4KV
Protection degree	IP00
Detuning factor (p%)	7% - 14%

Constructive Characteristics - Three phase harmonic filters are made of low losses magnetic plates, permanent regime class F (1550C) copper conductor and thermal protection relay.

With the purpose of increasing filters ventilation, windings are separated among them, improving thermal dissipation.

Available factor p is 7% and 14% with resonance frequency 189 Hz and 134 Hz for 50 Hz networks.

With this standard values in three phase networks and balanced loads, the 5th (250 Hz) harmonic and higher resonant phenomenons are eliminated avoiding resonance between inductive impedance and three phase capacitors for power factor correction and preventing network capacitors and capacitor banks for overloads, caused by harmonics.

Table selection of three-phase harmonic filters for capacitor banks

400V-50Hz-7%-189Hz Copper

Type	Reactive power (kVAR)	Code No.	Power loss (W)	Inductance (mH)	Suggested Capacitance μ F	Rated current (A) Ieff	Weight (kg)	Capacitors
HFL 7/5 Cu	5	004656800	30	7,66	3x 30,84	7,2	7,5	2x LPC 3 kVAR, 460V, 50Hz
HFL 7/10 Cu	10	004656801	60	3,83	3x 61,67	14,4	8,5	LPC 12.5 kVAR, 460V, 50Hz
HFL 7/12,5 Cu	12,5	004656802	70	3,07	3x 77,09	18	9	LPC 15 kVAR, 460V, 50Hz
HFL 7/15 Cu	15	004656803	80	2,56	3x 92,51	21,7	9,5	LPC 20 kVAR, 480V, 50Hz
HFL 7/20 Cu	20	004656804	100	1,92	3x 123,35	28,9	16	LPC 25 kVAR, 460V, 50Hz
HFL 7/25 Cu	25	004656805	110	1,53	3x 154,18	36,1	16,5	LPC 30 kVAR, 460V, 50Hz
HFL 7/30 Cu	30	004656806	120	1,28	3x 185,02	43,3	17,5	LPC 40 kVAR, 480V, 50Hz
HFL 7/40 Cu	40	004656807	150	0,96	3x 246,69	57,7	28,5	LPC 50 kVAR, 460V, 50Hz
HFL 7/50 Cu	50	004656808	180	0,77	3x 308,36	72,2	30	2x LPC 30.8 kVAR, 460V, 50Hz
HFL 7/100 Cu	100	004656809	350	0,38	3x 616,73	144	43	4x LPC 30.8 kVAR, 460V, 50Hz

400V-50Hz-14%-134Hz Copper

Type	Reactive power (kVAR)	Code No.	Power loss (W)	Inductance (mH)	Suggested Capacitance μ F	Rated current (A) Ieff	Weight (kg)	Capacitors
HFL 14/5 Cu	5	004656810	60	16,58	3x 28,52	7,2	15	2x LPC 3 kVAR, 480V, 50Hz
HFL 14/10 Cu	10	004656811	90	8,29	3x 57,03	14,4	15	LPC 15 kVAR, 525V, 50Hz
HFL 14/12,5 Cu	12,5	004656812	120	6,63	3x 71,29	18	16	LPC 15 kVAR, 480V, 50Hz
HFL 14/15 Cu	15	004656813	150	5,53	3x 85,55	21,7	16	LPC 20 kVAR, 480V, 50Hz
HFL 14/20 Cu	20	004656814	150	4,15	3x 114,06	28,9	19,5	LPC 25 kVAR, 480V, 50Hz
HFL 14/25 Cu	25	004656815	190	3,32	3x 142,58	36,1	20,5	LPC 30 kVAR, 480V, 50Hz
HFL 14/30 Cu	30	004656816	220	2,76	3x 171,09	43,3	31	LPC 40 kVAR, 480V, 50Hz
HFL 14/40 Cu	40	004656817	290	2,07	3x 228,12	57,7	34,5	LPC 50 kVAR, 480V, 50Hz
HFL 14/50 Cu	50	004656818	330	1,66	3x 285,15	72,2	37	2x LPC 30 kVAR, 480V, 50Hz

400V-50Hz-7%-189Hz Aluminium

Type	Reactive power (kVAR)	Code No.	Power loss (W)	Inductance (mH)	Suggested Capacitance μ F	Rated current (A) Ieff	Weight (kg)	Capacitors
HFL 7/20 Al	20	004656820	100	1,92	3x 123,35	28,9	14,5	LPC 25 kVAR, 460V, 50Hz
HFL 7/25 Al	25	004656821	120	1,53	3x 154,18	36,1	17	LPC 30 kVAR, 460V, 50Hz
HFL 7/30 Al	30	004656822	130	1,28	3x 185,02	43,3	26	LPC 40 kVAR, 480V, 50Hz
HFL 7/40 Al	40	004656823	160	0,96	3x 246,69	57,7	26,5	LPC 50 kVAR, 460V, 50Hz
HFL 7/50 Al	50	004656824	200	0,77	3x 308,36	72,2	27	2x LPC 30.8 kVAR, 460V, 50Hz

400V-50Hz-14%-134Hz Aluminium

Type	Reactive power (kVAr)	Code No.	Power loss (W)	Inductance (mH)	Suggested Capacitance μ F	Rated current (A) I _{eff}	Weight (kg)	Capacitors
HFL 14/20 Al	20	004656830	170	4,15	3x 114,06	28,9	27	LPC 25 kVAr, 480V, 50Hz
HFL 14/25 Al	25	004656831	200	3,32	3x 142,58	36,1	27	LPC 30 kVAr, 480V, 50Hz
HFL 14/30 Al	30	004656832	240	2,76	3x 171,09	43,3	44	LPC 40 kVAr, 480V, 50Hz
HFL 14/40 Al	40	004656833	290	2,07	3x 228,12	57,7	44,5	LPC 50 kVAr, 480V, 50Hz
HFL 14/50 Al	50	004656834	370	1,66	3x 285,15	72,2	45	2x LPC 30 kVAr, 480V, 50Hz

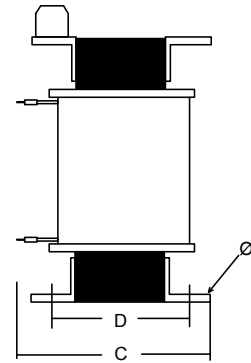
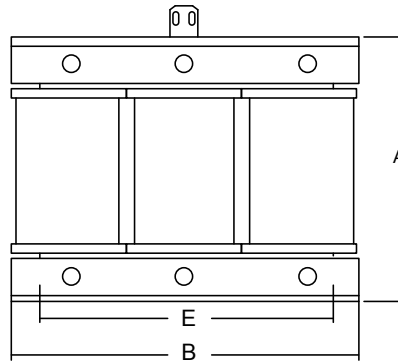
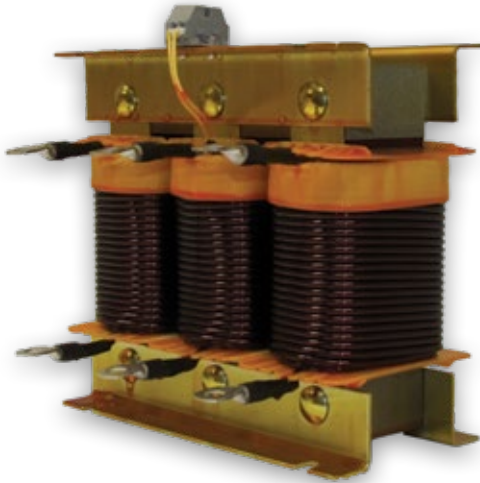

Copper Wire Reactors – Mechanical Dimensions

Type	Dimensions mm					
Cu	A	B	C	D	E	Φ
HFL 7/5 Cu	170	180	80	70	140	9
HFL 7/10 Cu	170	180	90	80	140	9
HFL 7/12,5 Cu	170	180	90	80	140	9
HFL 7/15 Cu	170	180	90	80	140	9
HFL 7/20 Cu	220	240	100	90	200	9
HFL 7/25 Cu	220	240	100	90	200	9
HFL 7/30 Cu	220	240	100	90	200	9
HFL 7/40 Cu	270	300	120	100	200	9
HFL 7/50 Cu	270	300	120	100	200	9
HFL 7/100 Cu	320	360	150	125	300	9

Copper Wire Reactors – Mechanical Dimensions

Type	Dimensions mm					
Cu	A	B	C	D	E	Φ
HFL 14/5 Cu	220	240	100	90	200	9
HFL 14/10 Cu	220	240	100	90	200	9
HFL 14/12,5 Cu	220	240	100	90	200	9
HFL 14/15 Cu	220	240	100	90	200	9
HFL 14/20 Cu	220	240	110	100	200	9
HFL 14/25 Cu	220	240	110	100	200	9
HFL 14/30 Cu	270	300	120	100	200	9
HFL 14/40 Cu	270	300	130	110	200	9
HFL 14/50 Cu	270	300	130	110	200	9

Aluminum Wire Reactors – Mechanical Dimensions

Type	Dimensions mm					
Al	A	B	C	D	E	Φ
HFL 7/20 Al	220	240	100	90	200	9
HFL 7/25 Al	220	240	110	100	200	9
HFL 7/30 Al	270	300	120	100	200	9
HFL 7/40 Al	270	300	120	100	200	9
HFL 7/50 Al	270	300	120	100	200	9

Aluminum Wire Reactors – Mechanical Dimensions

Type	Dimensions mm					
Al	A	B	C	D	E	Φ
HFL 14/20 Al	270	300	120	100	200	9
HFL 14/25 Al	270	300	120	100	200	9
HFL 14/30 Al	320	360	160	135	300	9
HFL 14/40 Al	320	360	160	135	300	9
HFL 14/50 Al	320	360	160	135	300	9